



**NanoFil™**

*Microsyringe for nanoliter injection*



**World Precision Instruments, Inc.**

**USA**

International Trade Center, 175 Sarasota Center Blvd., Sarasota FL 34240-9258  
Tel: 941-371-1003 • Fax: 941-377-5428 • E-mail: sales@wpiinc.com

**UK**

Astonbury Farm Business Centre • Aston, Stevenage, Hertfordshire SG2 7EG  
Tel: 01438-880025 • Fax: 01438-880026 • E-mail: wpiuk@wpi-europe.com

**Germany**

Liegnitzer Str. 15, D-10999 Berlin  
Tel: 030-6188845 • Fax: 030-6188670 • E-mail: wpide@wpi-europe.com

**China & Hong Kong**

WPI Shanghai Trading Co., Ltd.  
Rm 20a, No8 Dong Fang Rd., Lu Jia Zui Financial District, Shanghai PRC  
Tel: +86 688 85517 • E-mail: chinasales@china.wpiinc.com

**Internet**

[www.wpiinc.com](http://www.wpiinc.com) • [www.wpi-medical.com](http://www.wpi-medical.com)  
[www.nitricoxide.net](http://www.nitricoxide.net) • [www.pipetter.com](http://www.pipetter.com)

www.wpiinc.com

**INSTRUCTION MANUAL**

Serial No. \_\_\_\_\_

120408

**World Precision Instruments**

## WARRANTY

WPI (World Precision Instruments, Inc.) warrants to the original purchaser that this equipment, including its components and parts, shall be free from defects in material and workmanship for a period of 90 days from the date of receipt. WPI's obligation under this warranty shall be limited to repair or replacement, at WPI's option, of the equipment or defective components or parts upon receipt thereof f.o.b. WPI, Sarasota, Florida U.S.A. Return of a repaired instrument shall be f.o.b. Sarasota.

The above warranty is contingent upon normal usage and does not cover products which have been modified without WPI's approval or which have been subjected to unusual physical or electrical stress or on which the original identification marks have been removed or altered. The above warranty will not apply if adjustment, repair or parts replacement is required because of accident, neglect, misuse, failure of electric power, air conditioning, humidity control, or causes other than normal and ordinary usage.

To the extent that any of its equipment is furnished by a manufacturer other than WPI, the foregoing warranty shall be applicable only to the extent of the warranty furnished by such other manufacturer. This warranty will not apply to appearance terms, such as knobs, handles, dials or the like.

WPI makes no warranty of any kind, express or implied or statutory, including without limitation any warranties of merchantability and/or fitness for a particular purpose. WPI shall not be liable for any damages, whether direct, indirect, special or consequential arising from a failure of this product to operate in the manner desired by the user. WPI shall not be liable for any damage to data or property that may be caused directly or indirectly by use of this product.

## Claims and Returns

- Inspect all shipments upon receipt. Missing cartons or obvious damage to cartons should be noted on the delivery receipt before signing. Concealed loss or damage should be reported at once to the carrier and an inspection requested. All claims for shortage or damage must be made within 10 days after receipt of shipment. Claims for lost shipments must be made within 30 days of invoice or other notification of shipment. Please save damaged or pilfered cartons until claim settles. In some instances, photographic documentation may be required. Some items are time sensitive; WPI assumes no extended warranty or any liability for use beyond the date specified on the container.
- WPI cannot be held responsible for items damaged in shipment en route to us. Please enclose merchandise in its original shipping container to avoid damage from handling. We recommend that you insure merchandise when shipping. The customer is responsible for paying shipping expenses including adequate insurance on all items returned.
- Do not return any goods to WPI without obtaining prior approval and instructions (RMA#) from our returns department. Goods returned unauthorized or by collect freight may be refused. The RMA# must be clearly displayed on the outside of the box, or the package will not be accepted. Please contact the RMA department for a request form.
- Goods returned for repair must be reasonably clean and free of hazardous materials.
- A handling fee is charged for goods returned for exchange or credit. This fee may add up to 25% of the sale price depending on the condition of the item. Goods ordered in error are also subject to the handling fee.
- Equipment which was built as a special order cannot be returned.
- Always refer to the RMA# when contacting WPI to obtain a status of your returned item.
- For any other issues regarding a claim or return, please contact the RMA department.

**Warning: This equipment is not designed or intended for use on humans.**

## REORDER INFORMATION

- NANOFIL** NanoFil Syringe, 10 microliter  
**NANOFIL-100** NanoFil Syringe, 100 microliter  
*NanoFil syringe does not contain any injection needles. Needles must be purchased separately. It does include a 26-gauge beveled needle for backfilling.*

### Recommended Accessories

- RPE-KIT** Retinal Pigment Epithelium (RPE) Injection Kit: SilFlex tubing, gasket (2), holder, and blunt tipmix (33, 34, 35 and 36-gauge)  
**IO-KIT** Intraocular (IO) Injection Kit: SilFlex tubing, holder, gasket, and beveled tipmix (33, 34, 35 and 36-gauge)  
**NF33BL-2** 33-gauge blunt NanoFil needle (pkg of 2)  
**NF34BL-2** 34-gauge blunt NanoFil needle (pkg of 2)  
**NF35BL-2** 35-gauge blunt NanoFil needle (pkg of 2)  
**NF36BL2** 36-gauge blunt NanoFil needle (pkg of 2)  
**NF33BV-2** 33-gauge beveled NanoFil needle (pkg of 2)  
**NF34BV-2** 34-gauge beveled NanoFil needle (pkg of 2)  
**NF35BV-2** 35-gauge beveled NanoFil needle (pkg of 2)  
**NF36BV-2** 36-gauge beveled NanoFil needle (pkg of 2)  
**NF33FBL-2** 33-gauge Flexifil blunt NanoFil needle (pkg of 2)  
**NF33FBV-2** 33-gauge Flexifil beveled NanoFil needle (pkg of 2)  
**NF33-36BL** Assortment of 4 blunt NanoFil needles  
**NF33-36BV** Assortment of 4 beveled NanoFil needles  
**NFQ34-5** 34-gauge Flexible Quartz Tubing for filling (pkg 5)

### Replacement Parts

- NFINHLD** NanoFil Injection Holder  
**SILFLEX-2** SilFlex tubing (pkg of 2)  
**NFGSK-5** Spare Gasket for NanoFil and Holder (pkg of 5)

## CONTENTS

INTRODUCTION ..... 1  
 BEVELED OR BLUNT? CHOOSE THE RIGHT TIP ..... 2  
 TIP SIZE ..... 3  
     A. Using the syringe without RPE and IO injection kit..... 4  
     B. Using the syringe with RPE and IO injection kit ..... 6  
     C. Cleaning the system..... 8  
 TROUBLESHOOTING ..... 9  
     Problem 1 ..... 9  
     Problem 2 ..... 9  
     Problem 3 ..... 9  
 REORDER INFORMATION..... 10  
     Recommended Accessories..... 10  
     Replacement Parts..... 10  
 WARRANTY ..... 11

## TROUBLESHOOTING

### Problem 1



After the syringe has been stored for a period of time, the syringe will not pick up the solution even with the 26-gauge needle.

**Possible cause:** This is most likely due to leakage in the gasket. After a long period of storage, the gasket could become compressed and lose its sealing ability.

**Solution:** Tighten the nut to compress the gasket.

### Problem 2

When using the RPE or IO kit, the solution keeps flowing out of the needle tip after UMP3 pump has stopped pumping.

**Possible cause:** The most likely cause is a trapped air bubble in the syringe. Because the RPE and IO kits require a high pressure to inject, an air bubble trapped in the system will be compressed during injection. It will expand back to original size after the injection is finished, causing the solution to ooze out of the tip slowly.

**Solution:** Air bubbles MUST be removed before injection. It is especially important for the NANOFIL-100.

### Problem 3

The tip is blocked.

**Possible cause:** Particles getting trapped in the tip. Concentrated salt solutions such as those used in microinjection of this type can form crystals inside the needle or the syringe. This can corrode the tip.

**Solution:** Because of the small inner diameter, most blocked tips are very difficult to recover. However, here are some methods to unblock the tip that might work. Try using an Ultrasonic cleaner such as WPI's PUC to clean the tip for 5 to 10 minutes. This might shake the particles inside the tip loose. Or, reverse-mount the tip (front tip inside the syringe) into a syringe that has been loaded with fluid. Push the plunger to flush the tip backwards to push out any particles.

Micro4 Revision	60mm x 10mL Syringe Type	60mm x 100mL Syringe Type
H	M	G
J	L	G
K.1	L	G

**TIP:** Current Micro4 units display the version on power up. To identify the version of older Micro4 controllers, first look for a firmware label. If a label is not found, program the Micro4 for syringe Type L and enter a value of 170nL /sec. If the number displayed automatically switches to **169** then your unit is Rev. H. (Use syringe Type M and the setting of 0.5293 for the entry.) If the number remains **170**, the controller is Rev. J. (Use syringe Type L.)

**C. Cleaning the system**

When dried, protein or other high molecular weight reagents inside the syringe can clog the system. Saline solutions in the stainless needle can cause corrosion of the needle if not rinsed out, so it is important to rinse and dry the syringe and needle after each use. The entire system is made of materials that are resistant to most organic solutions. It can be cleaned using any organic solvent or chemical sterilization.

Autoclaving the NanoFil syringe is not recommended, since the adhesives and the Teflon seal will eventually breakdown or swell from the heat and pressures involved. The most practical method of sterilizing is either ethylene oxide (EtO) gas or Cidex (WPI # 7364) liquid chemical sterilization.

**CAUTION:** Chemicals that should be avoided include:

- Hydrofluoric acid (HF) damages the glass and quartz.
- Strong acid damages the stainless needle and plunger.

**INTRODUCTION**

**NanoFil™** is a unique 10 or 100µL syringe developed in response to customer requests for improved microinjection in mice and other small animals. It makes quantitative nanoliter injection much easier and more accurate than any other method currently in use.

**NANOFIL-100** is a 100µL NanoFil syringe. All the tip attachments for the original 10-microliter NanoFil can also be used with this syringe. The large volume of the syringe is useful for applications that require multiple injections. The speed of the flow at the tip can also be 10 times faster than the 10µL NanoFil when used with **UMP3** UltraMicroPump – which may be important for some applications. The limitation of the 100µL syringe is that the injection volume resolution is lower than that of the 10µL syringe.

The foundation of the design centers on reducing the tip size and dead volume of the system. The smallest metal needle offered for NanoFil is our exclusive 36-gauge (110µm) OD stainless steel needle. This needle is so small it can be inserted into the tip opening of a 33-gauge needle, previously the smallest-gauge available from any micro syringe manufacturer. Offered in both blunt and beveled styles, the tip will cause less damage to the tissue than other micro syringes on the market. In applications where a 36-gauge needle may be too small, slightly larger-gauges are also available. The full range includes 33, 34 and 35-gauge needles in both blunt and beveled styles.

In traditional nanoliter injection, the dead volume of the syringe and needle is backfilled with oil as a transfer medium. This makes the process messy and risks contamination of the injected sample. NanoFil’s low-volume flexible tubing eliminates the need for oil. Injection is now simpler and less messy, and there is no possibility of oil contamination in critical applications such as ophthalmology research (see the Retinal Pigment Epithelial (RPE) and Intra Ocular (IO) injection kits listed below).

Based on application requirements, NanoFil can be used in several different configurations:

- 1. Installed on WPI’s UMP3 UltraMicroPump:** This combination allows nanoliter resolution and reproducibility. For neural system injection, mount the UMP3 on a stereotaxic frame.
- 2. SilFlex tubing and holder:** The needle is mounted on a small plastic holder that is connected to the NanoFil by a 35cm length of flexible tubing. The NanoFil is mounted on the UMP3 pump. This configuration allows the user to hold the animal in one hand and insert the needle with the other. When the needle reaches the

desired location, activate the pump using the foot switch and the pre-programmed injection volume will be injected. This configuration gives a nanoliter level of accuracy and reproducibility. It is best suited for applications such as the RPE and IO injection.

**3. Direct injection by hand:** This is the simplest and most economical way to inject. Any of the tips (see table below) can be inserted directly into the NanoFil syringe. The limitation of this method is the difficulty in achieving sub-microliter resolution.

## BEVELED OR BLUNT? CHOOSE THE RIGHT TIP

The replaceable needles used with the NanoFil are available with either blunt or beveled tips. The blunt tip is used for injection into soft tissue and when a uniform solution distribution is needed. The beveled style is used for applications that involve the penetration of tough tissue.

One of the main factors that limit the resolution and accuracy of conventional micro syringes is diffusion from the large ID tip. When the tip ID is equal or larger than 100µm, the error caused by tip diffusion is in the nanoliter range level ( $[100\mu\text{m}]^3 = 1\text{nL}$ ). With a 36-gauge needle installed on the NanoFil, the error caused by diffusion is reduced to the sub-nanoliter level, making accurate injection of a nanoliter possible.

All of WPI's beveled tips have a unique 25° tri-surface bevel that is optimized for microinjection. A 10° single-surface beveled tip penetrates better than one with a 25° angle, however the distance between the

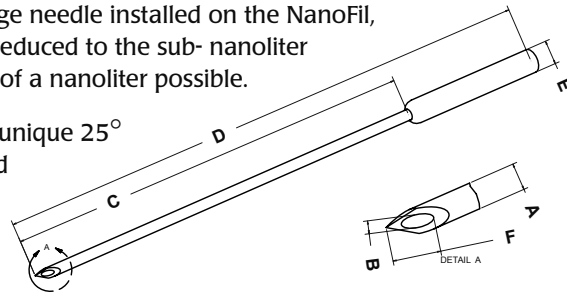

Fig. 1 – Tip dimensions.

Tip Order Number	Tip O.D. A	Tip I.D. B	Tip Length C	Total Length D	Shank O.D. E	Tip Material
NF33BV-2	210 µm	115 µm	10.0mm	40.0mm	460 µm	Stainless Steel
NF34BV-2	185 µm	85 µm	5.0mm	35.0mm	460 µm	Stainless Steel
NF35BV-2	135 µm	55 µm	5.0mm	35.0mm	460 µm	Stainless Steel
NF36BV-2	110 µm	35 µm	3.0mm	33.0mm	460 µm	Stainless Steel
NF33FBV-2	200 µm	100 µm	5.0mm	35.0mm	460 µm	Titanium Alloy
NFQ34-5	160 µm	100 µm	55.0mm	75.0mm	460 µm	Quartz

*Above dimensions apply to blunt tips also.*

26-gauge needle provided. Remove the 26-gauge needle and insert the SilFlex tubing with the opposite end coupled to the chosen tip. Force the cleaning solution out. An ultrasonic bath might also help to loosen particles in the tubing.

**2. Tip holder ⑥⑦.** The holder connects the SilFlex tubing with the injection tip. It has the same coupling mechanism used on the NanoFil syringe. The inside diameter of the barrel and gaskets are identical to the one on the syringe. Both tip and tubing should be installed by loosening the screw, inserting the tubing and tightening the nut finger-tight. The SilFlex is inserted through the red nut ⑥ on the back of the holder. Insert your tip of choice through the front cap ⑦. The length of the tip can be adjusted by sliding the tip up into the holder. The tip and SilFlex should be very close to each other inside the holder barrel, but not touching. Because the tubing will move forward as the screw is tightened, a gap between the tip and the tubing is essential to avoid crushing the tubing. The gap can be as large as 1mm while only increasing dead volume by 0.17µL. Because the SilFlex tubing is very soft, it might be difficult to “fish” it through the gasket during the installation. To solve this problem, unscrew the red nut and use forceps to take out the silicone gasket. Thread the nut and the gasket onto the SilFlex tubing. Then, with the red nut and gasket on, fit the SilFlex into the back hole of the holder ⑧. Using one hand to hold the SilFlex in the holder, slide the gasket and red nut into the holder and tighten it.

**3. Injection tip.** Any tip that can be used directly on the NanoFil syringe can also be used with the pipette holder and is installed in exactly the same way.

### Application

Assemble the SilFlex, tubing, tip holder and tip first without mounting the SilFlex into the NanoFil syringe. When the SilFlex is dry, the air trapped in the tubing will prevent it from being filled like a regular needle. The dead volume of the SilFlex is about 3µL. Therefore, the syringe needs to be pre-filled with a regular needle with more than 3 µL of fluid before installing the Silflex on to the NanoFil. (After the first injection is finished, the syringe can be filled directly from its tip, because the tubing will be filled with solution at that time.)

After filling the system, install the SilFlex and tip holder assembly and mount it on the **UMP3 UltraMicroPump**. Fast forward the plunger until a small amount of liquid comes out of the tip. The system is now ready for injection. Program UMP3's **Micro4** Controller for the volume to be injected. Use one hand to hold the animal and the other hand to place the needle into the injection site. Then use the foot switch to activate the pump for injecting a controlled amount of solution.

The NanoFil syringe is 60mm x 10µL (or 100µL) and has an inside diameter of 0.46mm (or 1.46mm). A engineering revision of the Micro4 necessitates use of a different syringe type.

## B. Using the syringe with RPE and IO injection kit

These kits are specially designed for “hands-free” and oil-free submicroliter injection. Originally developed for retinal pigment epithelium and intraocular injection, they can also be used for other applications. The injection volume is controlled by UMP3’s program and is activated by a foot switch. The “free hands” can be used to hold the animal and place the needle into the injection site. These kits need to be used with a NanoFil syringe and UMP3 to achieve accurate, repetitive and oil-free injection in the submicroliter range. Each kit includes two pieces of Silflex tubing (one for a spare), a tip holder, spare gaskets, and an assortment of four tips – blunt for the RPE kit and tri-surface beveled tips for the IO Kit. Each kit comes with one each of 33, 34, 35 and 36-gauge tips so that first time users can find the best size for their application.

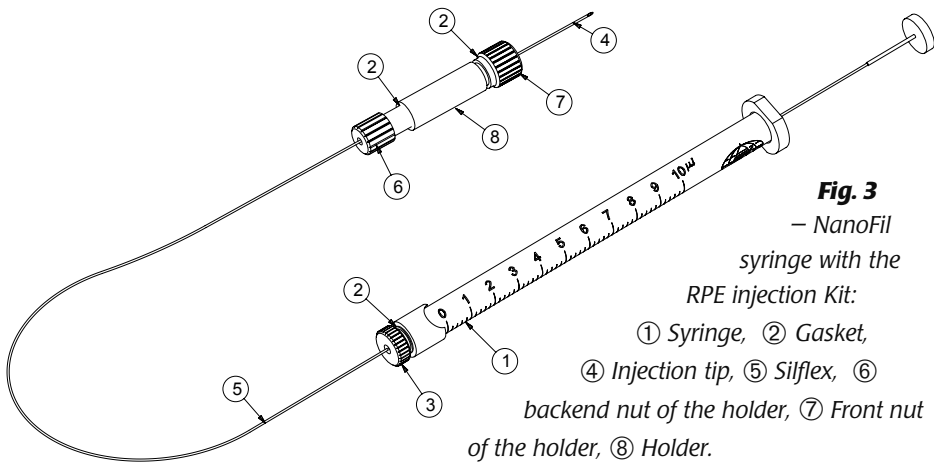

1. SilFlex (flexible and low dead volume tubing). This tubing is made of 100µm ID quartz tubing with a Teflon jacket making it a total 460µm OD. It is 350 mm long and the dead volume of the tubing section is about 3µL. The low dead volume, consistent inside diameter and flexibility are essential for the system. Special attention is needed when handling this tubing.



**CAUTION: Sharp bending can crack the glass and damage the tubing permanently. Do not bend it with a radius less than 30 mm or against a sharp corner.**

The tubing needs to be flushed with distilled water after use. Due to its small inside diameter, the tubing can become clogged with particles or proteins in solution. If clogged, flushing it from the opposite end of the tubing with a syringe might dislodge the particle. Load cleaning solution into the NanoFil syringe with the

upper opening to the tip (see dimension F in Figure 1) is longer. As a result, it requires a deeper penetration of the tip to achieve the same level of liquid delivery. Deeper penetration means more tissue damage. WPI’s unique 25° tri-surface bevel tip solves this problem with two extra beveled surfaces. The tip of a single surface beveled tip is actually a blade instead of a point. It dulls very quickly. In contrast, the tri-surfaced tip has a real point. It not only penetrates much better but is also much more durable. Tests show that WPI’s 33-gauge, 25° beveled tip penetrates easier and lasts longer than other manufacturers’ 33-gauge, 10° single-beveled tips. With a 35-gauge tri-surface beveled tip, the resistance to the penetration becomes even less. Each WPI tip undergoes a penetration test before leaving the factory to guarantee the best results.

## TIP SIZE

**36-gauge:** This is the smallest tip available – so small that it can be inserted into the lumen of a 33-gauge needle tip. Because this pushes the limit of what current technology can produce, there are some limitations to consider before using it. The small diameter makes it necessary to limit length to 2.5–3.0mm in order to maintain a usable strength. Since the tip ID is in the 25 to 50µm range, it is easily clogged. Therefore, only well-filtered solutions can be used. Depending on the viscosity of the sample, the user might also need to pre-load the syringe with a regular tip before switching to this tip for injection. We recommend using the 35-gauge tip instead of the 36-gauge unless experimental design requires the finer tip.

**35-gauge:** With its balanced combination of strength, length, durability and clog resistance, this was the most popular and preferred tip of most scientists during NanoFil’s field trial. It is much smaller than the 33-gauge tip and only slightly larger than the 36-gauge tip but is much stronger and less likely to clog. Samples can be directly loaded with this tip. Its 5mm length is sufficient for almost all injection applications in mice.

**34-gauge:** This is a transitional size between the 33-gauge and 35-gauge. If the 35-gauge is too weak and the 33-gauge is too large, 34-gauge is a good alternative.

**33-gauge:** This tip is similar to Hamilton’s 7762 and 7803 series removable needles in both tip length and outside diameter. However, WPI’s beveled tip version is shorter, more durable, and penetrates better due to the special tri-surface grinding technique. In the past, 33-gauge tips were the smallest size sold and were frequently cited in literature. However, our new 35-gauge tip is much better for injections involving small animals, especially mice. Compared with Hamilton’s 33-gauge, 10° beveled tip, WPI’s 35-gauge 25° beveled tip can reduce the depth of penetration

by almost 80%. The distance between the tip and the upper rim of the opening (dimension F on Figure 1) is 1024µm for the 33-gauge tip. On the 35-gauge tip, the distance is only 230µm. In addition, the smaller tip size significantly reduces the required penetration force. In nearly all applications, a 33-gauge tip can be replaced with WPI's 35-gauge tip and produce better results.

**FlexiFil:** The FlexiFil tip is made of a titanium alloy. The advantage of this tubing is its durability. This "semi-flexible" tip can be bent up to 90° without damage. It is also much more corrosion resistant than the stainless steel tip. Saline solutions left in the tip are less likely to clog. Although this tip is specified as a 33-gauge tip, its outside diameter is slightly smaller than our 33-gauge stainless steel tip.

**Flexible Quartz Tubing:** The flexible quartz tubing tip is made of 160µm OD polyimide coated quartz tubing with a special adapter sleeve mounted at the end. It is designed for filling glass capillary electrodes or pipettes, just like WPI's traditional MF34G Microfil. However, unlike the traditional MicroFil which has about 50µL of dead volume in its luer hub, the dead volume of this tip is less than 0.6 microliters. It is useful for loading electrodes with solutions that have a limited volume or are too expensive to waste.

The detailed dimension of each tip can be seen in Fig. 1.

**A. Using the syringe without RPE and IO injection kit**

**1. Installing or changing the tip.** Unlike conventional micro syringes, NanoFil has a unique tip coupling mechanism that holds straight tubing (or tips). The tubing can be made of metal, plastic or even glass. The OD of the tubing has to be close to but not larger than 0.460mm (see Figure 2). To replace the tip, turn the screw cap ③

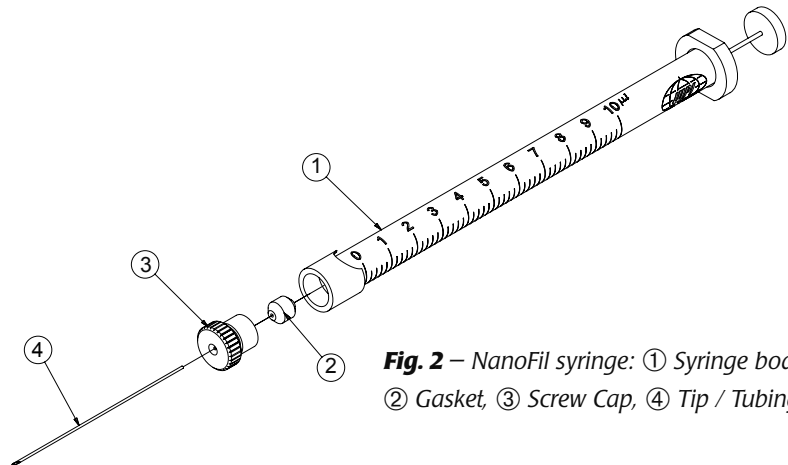

**Fig. 2 – NanoFil syringe:** ① Syringe body, ② Gasket, ③ Screw Cap, ④ Tip / Tubing.

counter-clockwise and pull the tip ④ out. Insert the new tip by slowly pushing it through the gasket ② and into the glass barrel of the syringe body. Let the end of the tip stop at the zero mark of the syringe and tighten the screw cap until it is "finger tight". **Do not use a wrench to tighten this cap.** A 26-gauge beveled needle is supplied with the syringe. This needle is for pre-loading the syringe when NanoFil is used with tips smaller than 35-gauge and SilFlex tubing included in the RPE and IO Kit.

**2. Filling the syringe.** When using the 33, 34 and 35-gauge needles, the syringe can be filled directly, just like a regular syringe. Push the plunger to zero. Immerse the tip of the syringe in the solution to be filled. Slowly pull the plunger back. If there is an air bubble in the barrel, it can be refilled. Sometimes, pushing the solution out quickly can force the remaining air out.

**CAUTION:** Please note that the syringe should be only operated when the barrel is wet. Otherwise, friction can damage the Teflon® tip of the plunger. Do not pull the plunger repeatedly when the barrel is dry.

**3. Using with 36-gauge tip.** For low viscosity solutions, it can be filled the same way as the larger tips. However, the solution should be drawn at much lower speed to prevent air bubbles from leaking in around the back of the plunger. Due to the small inner diameter of the tip, filling the syringe could be difficult with high viscosity solutions. If the regular filling method is not effective, the syringe needs to be pre-filled with the injection solution using the regular 26-gauge tip supplied with the syringe. Then, switch to the 36-gauge needle for injection.

**4. Using with smaller glass tips.** For applications that need tips smaller than the 36-gauge stainless needle, the user can pull their own glass tips from a glass or quartz capillary. The capillary needs to be close to but smaller than 460µm. If it is too big, it will not fit into the barrel of the syringe. If it is too small, the air trapped around the capillary will affect the performance. Please note that any tip that is smaller than 20µm in ID could be easily clogged by particles in the solution. To prevent clogging, the injection solution needs to be filtered. The capillary that is used for making the tip needs to be cleaned carefully, and the tip should be made in a clean-room environment. When using such small tips, the syringe barrel needs to be pre-filled with a large needle before installing the tip.

**WARNING:** When the tip is clogged, the plunger can generate a very high pressure exceeding 10,000 PSI due to the small cross sectional area of the piston. The gasket in the syringe will not be able to hold the tip in position under such a high pressure, so it may move or shoot out like a bullet. Therefore, **never point the syringe tip at a person, and always use protective glasses when using the very small tip.**