



MMP & DMP

Manual Microsyringe Pumps

INSTRUCTION MANUAL

Serial No. _____

www.wpiinc.com

121410

World Precision Instruments



CONTENTS

INTRODUCTION	5
Parts Included.....	6
INJECTION FLUID FILLING	7
IMPROVING PERFORMANCE	8
Shortening the Teflon Tubing	9
Removing Air from the Pipette Coupling Tube.....	9
Removing the Stopcock.....	9
DETERMINATION OF TOTAL VOLUME PUMPED	10
ACCESSORIES.....	11
Syringes for MMP/DMP.....	11
Replacement Parts.....	11
SPECIFICATIONS.....	11
WARRANTY	13
Claims and Returns	13
Repairs	13

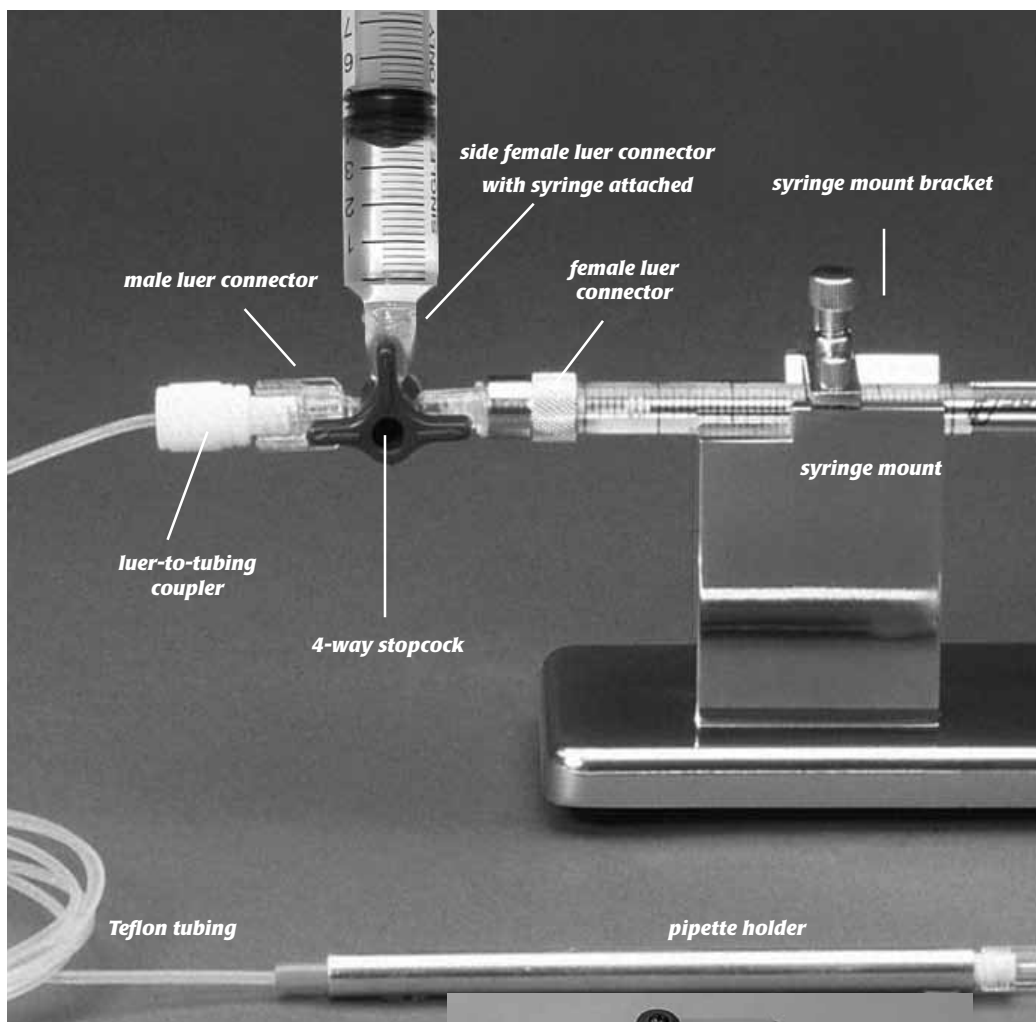
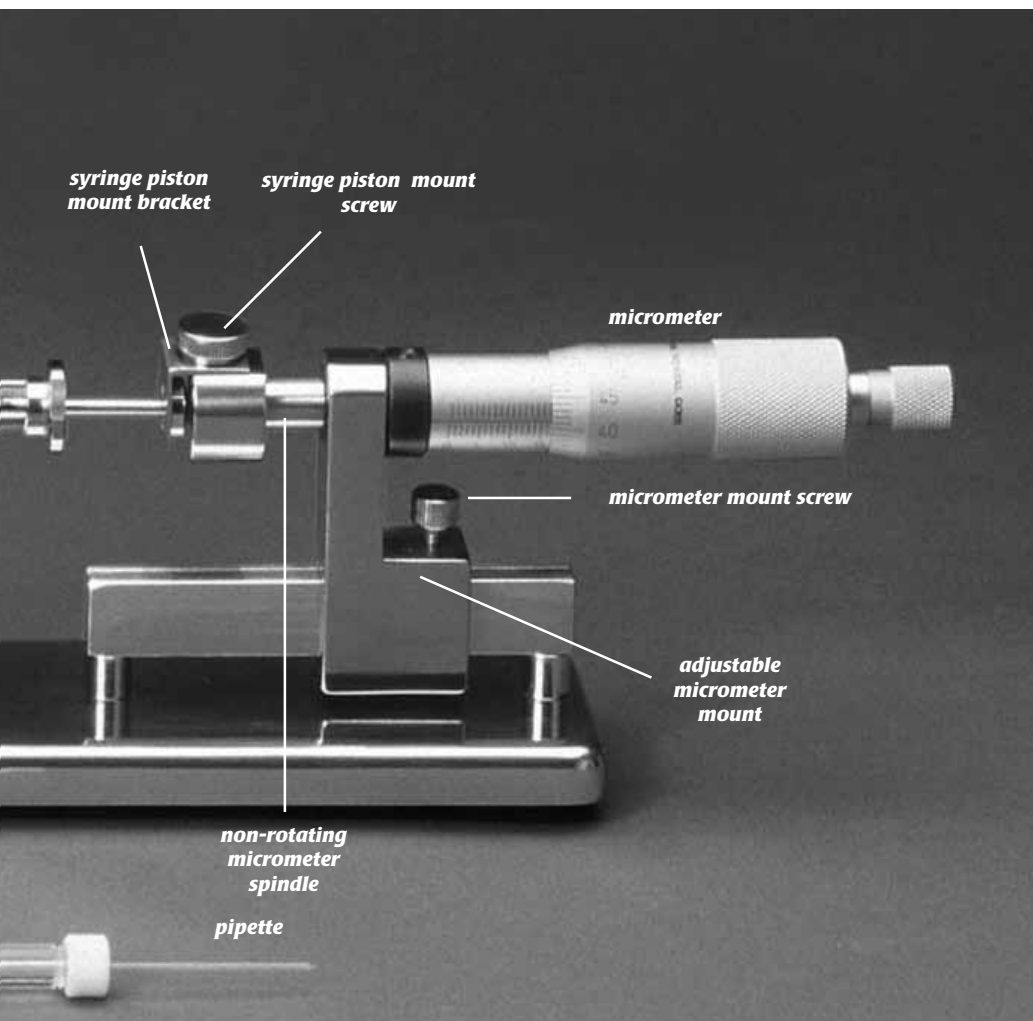

Fig. 1— MMP Manual Microsyringe Pump is shown fully assembled.

Fig. 2— On the DMP the micrometer has a digital display





INTRODUCTION

The **MMP** is a convenient tool for precise manual injection of fluid using glass pipettes or similar injection devices. **DMP** has a digital micrometer head for increased precision and ease of use. The design allows visual feedback of flow at the pipette tip and can also be used as a manual micro syringe pump for perfusion or withdrawal of liquids. The resolution of the injection volume can be continuously varied from 10nL to the microliter range, depending on the syringe volume used. Either oil or air can be used as the transfer media to assist in the injection of fluid.

The non-rotating micrometer head has a resolution of 10µm per division and advances 500µm per full revolution. The entire frame body of the injector is constructed with polished stainless steel for stability and durability. The piston of the micrometer can be slid across the rail to the syringe's plunger position. Small diameter PTFE tubing is used to improve the accuracy and solution compatibility. The unique design of the pipette holder can securely hold any pipette with an outer diameter of between 1.0mm and 1.5mm. The necessary accessories for removing air and filling the syringe and tubing with liquid are included. The system comes complete with a 100µL gas tight syringe. However, other syringe sizes are available on request.

Parts Included

- Stainless steel stand with micrometer
- 100µL gas-tight SGE syringe (#**SGE100TLL**)
- 4-way stopcock (#**14057-10**)
- 10mL plastic syringe (#**3744-10**)
- Injection assembly (pipette holder, Teflon tubing, luer-to-tubing coupler, gasket for 1.0mm OD pipette)
- Extra gasket for 1.0mm OD pipette (Green Silicone)
- Extra gasket for 1.2mm OD pipette (Black Silicone)
- Extra gasket for 1.5mm OD pipette (Blue Silicone)
- Extra gasket for 1.65mm OD pipette (Red Silicone)
- Digital Micrometer Head (model **DMP** only), packed separately to reduce risk of damage during shipment. To install, slide it all the way onto the hole in the adjustable micrometer mount, then attach the syringe piston mount bracket as shown in **Fig. 1**. Tighten the screws on the side of the syringe bracket and micrometer mount with the tool provided.

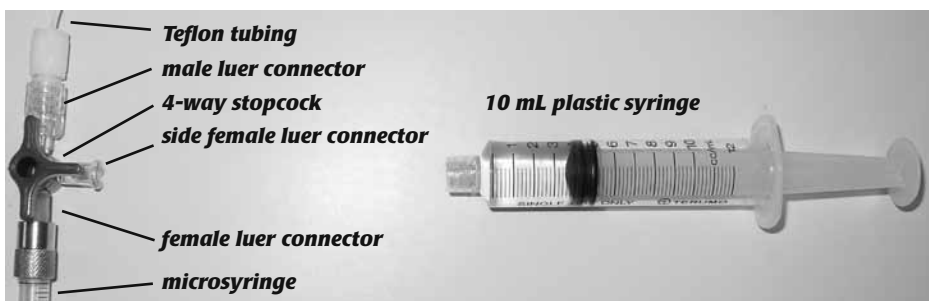

Fig. 3—Fluid injection components

INJECTION FLUID FILLING

The MMP/DMP can be used with either oil or air as the transfer medium. In general, however, only 500 μ L or 1000 μ L syringes (not included) are used with air, because of the compressibility of air. Almost a microliter may have to be pumped before the pressure builds up to the point where the response in the pipette is as fast as with a liquid. Therefore, an oil-based transfer medium such as silicone oil, mineral oil or Fluorinert should be used, if precision in the nanoliter range is desired.

The 10mL plastic syringe provided with the MMP/DMP is used to fill both the micro syringe and the Teflon tubing with the injection fluid of your choice. The procedure described in this section is designed to maximize the removal of air bubbles, which would otherwise slow the response time of the MMP/DMP and decrease its precision when dealing with very small injection volumes.

TIP: If it is desirable to have the microsyringe mounted during this process, the syringe piston will be easier to move if the micrometer mount screw is loosened so that the entire micrometer mount can be slid across the base of the MMP/DMP.

NOTE: Please read through all of the instructions before beginning.

1. Disconnect everything from the stopcock and fill both syringes with the injection fluid.
2. Attach the 10mL syringe to the side female luer connector of the stopcock.
3. Turn the knob of the stopcock to the position shown in Fig. 4 (**MFS position**). The stopcock valve allows four different flow paths between the female luer, male luer, and side female luer connectors (Figs. 4-7).

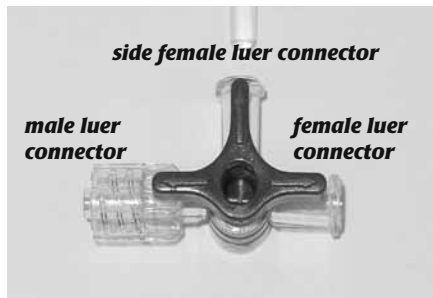









Fig. 4—Male, female and side luers are open (MFS position)

Valve Position	Flow Path
Fig. 4 	
Fig. 5 	
Fig. 6 	
Fig. 7 	

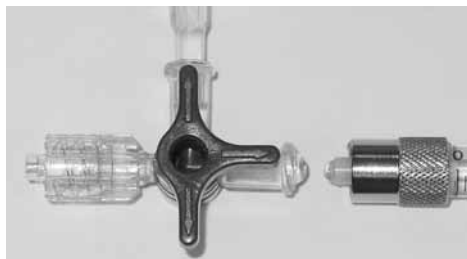

Fig.5—Female and side luers are open (FS position)

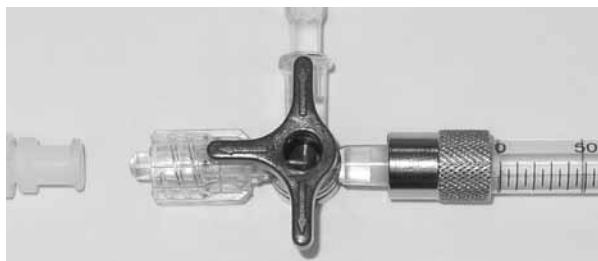

Fig. 5—Female and side luers are open (MS position)

the valve of the stopcock. Then turn it clockwise to the position shown in Fig. 4 so that the male luer connector is blocked off (**FS position**) and attach the micro syringe.

If there are any bubbles between the micro syringe and stopcock they can be expelled into the Teflon tubing after turning the knob to the **MF position** (Fig. 6). Then, turn it back to the **FS position** so that it can be refilled with the 10mL syringe. This procedure may have to be repeated with the smaller micro syringe sizes. Once a bubble free connection is established with the micro syringe, put the stopcock knob in the **MS position** (Fig. 5), attach the Teflon tubing and pipette, and advance the piston of the plastic syringe until all air is expelled.

Turn the knob to the **MF position** so that the micro syringe is connected exclusively to the Teflon

tubing as shown in Fig. 6. If any bubbles enter the system around the stopcock during use, expel them directly into the plastic 10mL syringe.



Fig. 6—Male and female luers are open (MF position)

For each step in the filling process, make sure the luer tips are filled with the fluid before connecting them so that bubble formation is minimized.

4. Advance the piston of the large plastic syringe until the open ends of the stopcock are at least partially full (Fig. 5). This displaces trapped air within

IMPROVING PERFORMANCE

For most cases, the precision obtained from following the steps in the previous section is adequate. If more precision is required, it may be desirable to try the following techniques and modifications.



CAUTION: Pipette holder and luer-to-tubing couplers are very small and may be easily misplaced.

Shortening the Teflon Tubing

In general, the MMP will work better if the Teflon tubing is as short as is convenient for a given application. Although the tubing is very stiff, it still may expand and contract slightly from the pressure generated by the micro syringe. In addition, the higher pressure needed to push the injection fluid through a longer tube increases the chance that air will slip through one of the seals. In order to shorten the tubing, one of the ends must be exposed so that it can be cut. The easiest way to do this is to unscrew the end cap of the luer-to-tubing coupler (Fig. 7).

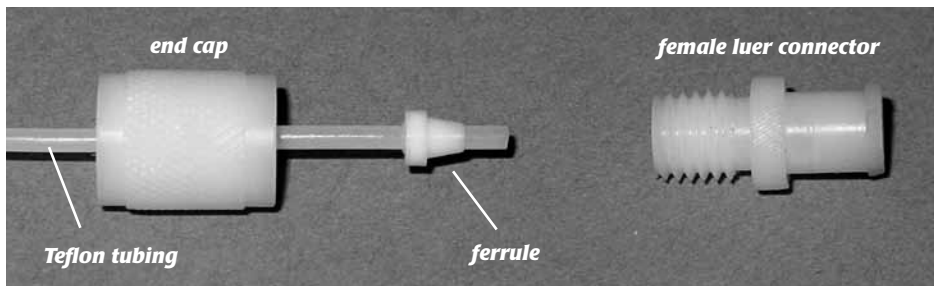

Fig. 7—Luer to tubing coupler parts

Removing Air from the Pipette Coupling Tube

Since the pipette coupling tube must accommodate both the Teflon tubing and a range of pipette sizes, there will generally be enough dead volume outside the main fluid passage for air to get trapped in. If the pipette holder is taken apart (Fig. 8), a bubble-free connection can be achieved when each end of the coupling tube is filled with injection fluid before it is re-assembled. As the ends of the Teflon tubing and pipette are slipped into the coupling tube, make sure they meet in the middle so that dead volume is minimized and the risk of bubble formation is reduced.

Removing the Stopcock

The stopcock contains a lot of dead volume. The MMP/DMP can be used without it, though this will make it more difficult to set up, and there is no easy way to remove

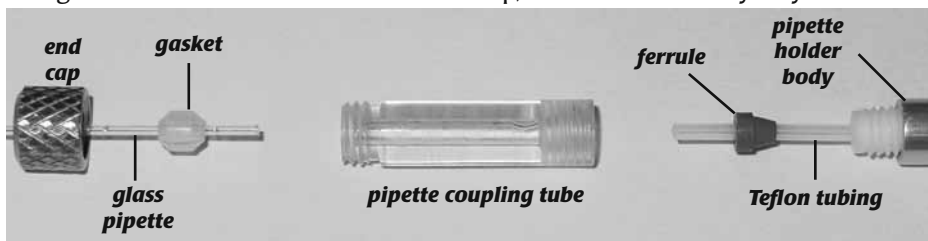

Fig. 8—Pipette holder parts

bubbles that form during use. However, it might improve performance slightly for some applications.

First, load the Teflon tubing directly with the 10mL syringe. Continue to eject fluid out of the syringe as it is being separated from the tubing so that the female luer to tubing coupler remains full. Attach the tubing to the micro syringe with both luer connectors completely filled with injection fluid so that no air is introduced into the system. Since even small bubbles will make more difference than the presence of the stopcock, this step should be performed very carefully and re-tried, if necessary. Finally, be sure to remove trapped air from the pipette coupling tube and the micro syringe itself.

DETERMINATION OF TOTAL VOLUME PUMPED

The micrometer head advances 10 μ m/division and 500 μ m/turn. First, measure the total travel distance of the syringe with calipers. Divide the total volume by the measured value. Multiply this figure by the constants above to get nL per division and per turn.

Example: The SGE 100 μ L gas tight luer lock syringe (WPI# **SGE0100TLL**) is 60mm from the "0 μ L" mark to the "100 μ L" mark.

$$(100\mu\text{L}/60\text{mm}) \cdot (1\text{mm}/1000\mu\text{m}) \cdot (1000\text{nL}/\mu\text{L}) = 1.6667\text{nL}/\text{micron}$$

$$(1.6667\text{nL}/\mu\text{m}) \cdot (10\mu\text{m}/\text{division}) = 16.667\text{nL}/\text{division}$$

$$(1.6667\text{nL}/\mu\text{m}) \cdot (500\mu\text{m}/\text{turn}) = 833.33\text{nL}/\text{turn}$$

ACCESSORIES

MMP-KIT	Injection Assembly Parts Kit — <i>contains injection assembly (pipette holder, Teflon tubing, luer-to-tubing coupler, gaskets for 1.0mm OD pipette, 1.2mm OD pipette, 1.5mm OD pipette, 1.65mm OD pipette)</i>
14057-10	4-Way Stopcock, Luer Lock

Syringes for MMP/DMP

WPI P/N	Description	nL/div.	nL/turn
ILS025LT	ILS 25 μ L Gas-tight Luer tip	4.1666	208.33
SGE050TLL	SGE 50 μ L Gas-tight Teflon Luer Lock	8.3333	416.66
SGE100TLL	SGE 100 μ L Gas-tight Teflon Luer Lock	16.6666	833.33
SGE250TLL	SGE 250 μ L Gas-tight Teflon Luer Lock	41.6666	2083.33
SGE500TLL	SGE 500 μ L Gas-tight Teflon Luer Lock	83.3333	4166.66
SGE1000TLL	SGE 1000 μ L Gas-tight Teflon Luer Lock	166.6666	8333.33

Replacement Parts

75122-110	PicoNozzle gasket green 1.0mm, pkg. of 10
75122-210	PicoNozzle gasket black 1.2mm, pkg. of 10
75122-310	PicoNozzle gasket blue 1.5mm, pkg. of 10
75122-410	PicoNozzle gasket red 1.65mm, pkg. of 10

SPECIFICATIONS

Travel Distance.....	25mm
Advances per Revolution.....	0.5mm
Minimum Injection Volume.....	~10nL/div. for 100 μ L syringe
Syringe Size.....	10 μ L to 1mL gas tight luer tip syringe from SGE and Hamilton
Tubing.....	1.5m of PTFE tubing with 0.5mm ID
Pipette Holder Fits.....	1.0 to 1.65mm OD pipette



WARRANTY

WPI (World Precision Instruments, Inc.) warrants to the original purchaser that this equipment, including its components and parts, shall be free from defects in material and workmanship for a period of 30 days* from the date of receipt. WPI's obligation under this warranty shall be limited to repair or replacement, at WPI's option, of the equipment or defective components or parts upon receipt thereof f.o.b. WPI, Sarasota, Florida U.S.A. Return of a repaired instrument shall be f.o.b. Sarasota.

The above warranty is contingent upon normal usage and does not cover products which have been modified without WPI's approval or which have been subjected to unusual physical or electrical stress or on which the original identification marks have been removed or altered. The above warranty will not apply if adjustment, repair or parts replacement is required because of accident, neglect, misuse, failure of electric power, air conditioning, humidity control, or causes other than normal and ordinary usage.

To the extent that any of its equipment is furnished by a manufacturer other than WPI, the foregoing warranty shall be applicable only to the extent of the warranty furnished by such other manufacturer. This warranty will not apply to appearance terms, such as knobs, handles, dials or the like.

WPI makes no warranty of any kind, express or implied or statutory, including without limitation any warranties of merchantability and/or fitness for a particular purpose. WPI shall not be liable for any damages, whether direct, indirect, special or consequential arising from a failure of this product to operate in the manner desired by the user. WPI shall not be liable for any damage to data or property that may be caused directly or indirectly by use of this product.

Claims and Returns

Inspect all shipments upon receipt. Missing cartons or obvious damage to cartons should be noted on the delivery receipt before signing. Concealed loss or damage should be reported at once to the carrier and an inspection requested. All claims for shortage or damage must be made within ten (10) days after receipt of shipment. Claims for lost shipments must be made within thirty (30) days of receipt of invoice or other notification of shipment. Please save damaged or pilfered cartons until claim is settled. In some instances, photographic documentation may be required. Some items are time-sensitive; WPI assumes no extended warranty or any liability for use beyond the date specified on the container

Do not return any goods to us without obtaining prior approval and instructions from our Returns Department. Goods returned (unauthorized) by collect freight may be refused. Goods accepted for restocking will be exchanged or credited to your WPI account. Goods returned which were ordered by customers in error are subject to a 25% restocking charge. Equipment which was built as a special order cannot be returned.

Repairs

Contact our Customer Service Department for assistance in the repair of apparatus. Do not return goods until instructions have been received. Returned items must be securely packed to prevent further damage in transit. The Customer is responsible for paying shipping expenses, including adequate insurance on all items returned for repairs. Identification of the item(s) by model number, name, as well as complete description of the difficulties experienced should be written on the repair purchase order and on a tag attached to the item.

** Electrodes, batteries and other consumable parts are warranted for 30 days only from the date on which the customer receives these items.*







World Precision Instruments, Inc.

USA

International Trade Center, 175 Sarasota Center Blvd., Sarasota FL 34240-9258
Tel: 941-371-1003 • Fax: 941-377-5428 • E-mail: sales@wpiinc.com

UK

Astonbury Farm Business Centre • Aston, Stevenage, Hertfordshire SG2 7EG
Tel: 01438-880025 • Fax: 01438-880026 • E-mail: wpiuk@wpi-europe.com

Germany

Zossener Str. 55, 10961 Berlin
Tel: 030-6188845 • Fax: 030-6188670 • E-mail: wpide@wpi-europe.com

China & Hong Kong

WPI Shanghai Trading Co., Ltd.
Rm 20a, No8 Dong Fang Rd., Lu Jia Zui Financial District, Shanghai PRC
Tel: +86 688 85517 • E-mail: chinasales@china.wpiinc.com

Internet

www.wpiinc.com